

DEHNdetect

Lightning current measuring system for detecting lightning events



Invest in availability and make your wind turbine a dependable source of power – now and in the future.

DEHNdetect reliably detects lightning events preventing expensive maintenance work and long downtimes. Damage resulting from a lightning strike does not necessarily lead to the immediate failure of the turbine and, as a result, lightning events often remain undetected. Especially in the case of upward flashes the initial long stroke current flowing is only a few 100A and can be the main cause of melting, e.g., on the receptors of rotor blades. The resulting subsequent damage may be severe. The revised standard IEC 61400-24 (July 2019) Wind turbines Part 24: Lightning protection recommends the installation of measuring systems which can also measure long stroke currents in order to determine the intensity of lightning strikes.

DEHNdetect not only recognises peak currents but also these dangerous long stroke currents and can, moreover, be equipped with optional rotor blade detection. The system can be integrated in the IT infrastructure of the wind turbine via existing interfaces. The data can then simply be read out and managed using the available SCADA systems. If direct integration is not possible, the data can be transmitted to a cloud¹⁾. The current curve can be evaluated in detail in this web application. This makes it possible to monitor several turbines or even entire wind parks.

Just get in touch with us – we will be happy to advise you!

Your advantages:

- Prevention of subsequent damage
- Optimisation of maintenance work and servicing
- Reduction of downtime

DEHNdetect determines the following parameters:

- Impulse current [kA]
- Specific energy [MJ/Ω]
- Load [C]
- Long stroke current [A]
- Rise time [kA/μs]

Further information:
de.hn/ddeen2

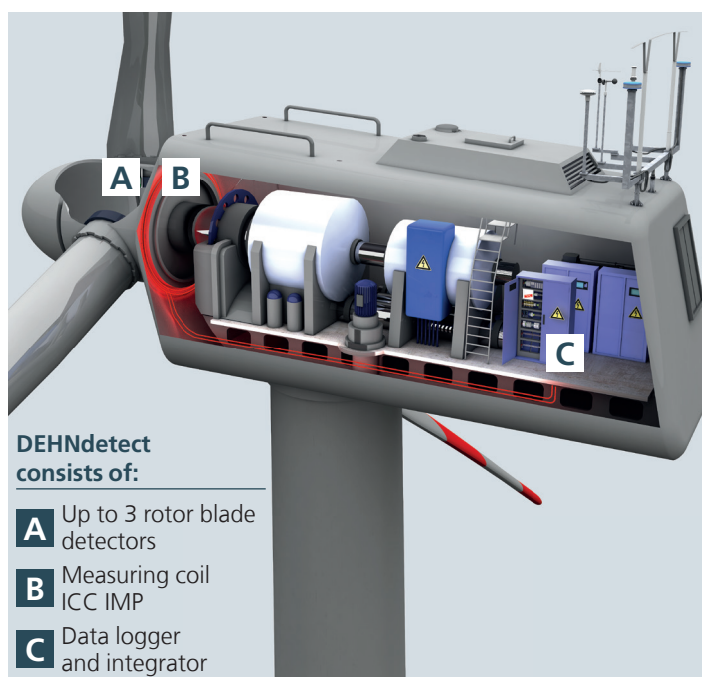

DEHNdetect consists of:

- A** Up to 3 rotor blade detectors
- B** Measuring coil ICC IMP
- C** Data logger and integrator

Exemplary installation of the lightning current measuring system.

DEHNdetect components	
	DEHNdetect DL Data logger with different interfaces for integration in IT systems.
	DEHNdetect Integrator Processing of the measuring signals and transmission to the data logger.
	DEHNdetect ICC IMP Measuring coil for measuring long stroke and impulse currents. Measuring range 60 A to 250 kA.
	DEHNdetect BDU Detector for the wireless detection of lightning current in the rotor blade.

¹⁾ Features depend on the configuration used

System configurations

The lightning current measuring system is flexible to configure and available in the following versions. An extension to the full version is possible at any time, even retrospectively.

Basic Version	Gives information about:
<ul style="list-style-type: none"> 1x Data logger 3x Rotor blade detectors 	<ul style="list-style-type: none"> Time of the event Which blade was hit by the lightning Level of the strike (> 100 A or > 5 kA)
Medium Version	Gives information about:
<ul style="list-style-type: none"> 1x Data logger 1x Rogowski coil + integrator 	<ul style="list-style-type: none"> Time of the event Detailed information about lightning parameters (current, charge, rise time, specific energy)
Full Version	Gives information about:
<ul style="list-style-type: none"> 1x Data logger 3x Rotor blade detectors 1x Rogowski coil + integrator 	<ul style="list-style-type: none"> Time of the event Detailed information about lightning parameters (current, charge, rise time, specific energy) Which blade was hit by the lightning

Arrangement of the coil

The DEHNdetect measuring coil is flexible and can be mounted at several points in the wind turbine. It is important that all lightning current-carrying components are encompassed by the coil.

1 At the transition between hub and nacelle

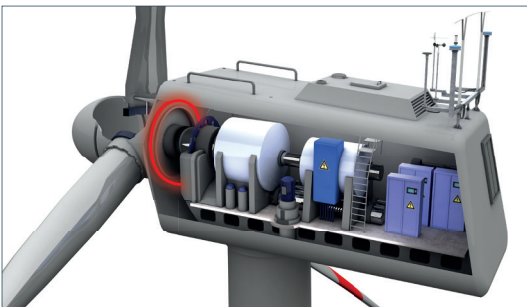

3 At the bottom of the tower

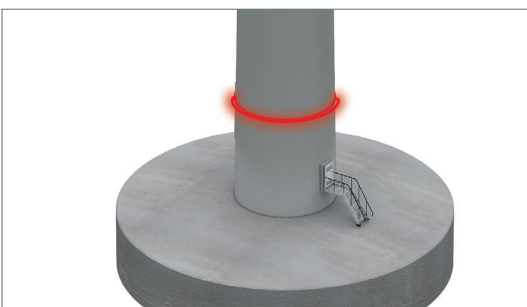

2 At the transition between nacelle and tower (e.g. around the yaw system)

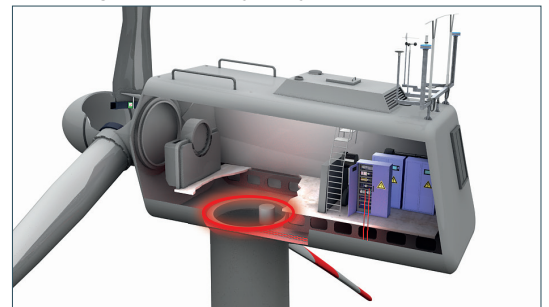

Note:
The figures show the measuring coil in red at the respective installation location.

Respond at lightning speed with **DEHNdetect** and reduce downtime

Our system experts will be happy to advise you:

Marjan Valand

✉ marjan.valand@dehn.de

☎ +49 9181 906-1505

Christian Vögerl

✉ christian.voegerl@dehn.de

☎ +49 9181 906-1633

